

Reproduction Masters for Model Rocketry

You may reproduce these pages for overhead projection transparencies or handout sheets so long as the copies are not sold and the Estes logo is clearly shown.

These masters are provided to you as a service to help you achieve maximum value in your educational program.

To use, detach this section (including dash line) before copying.

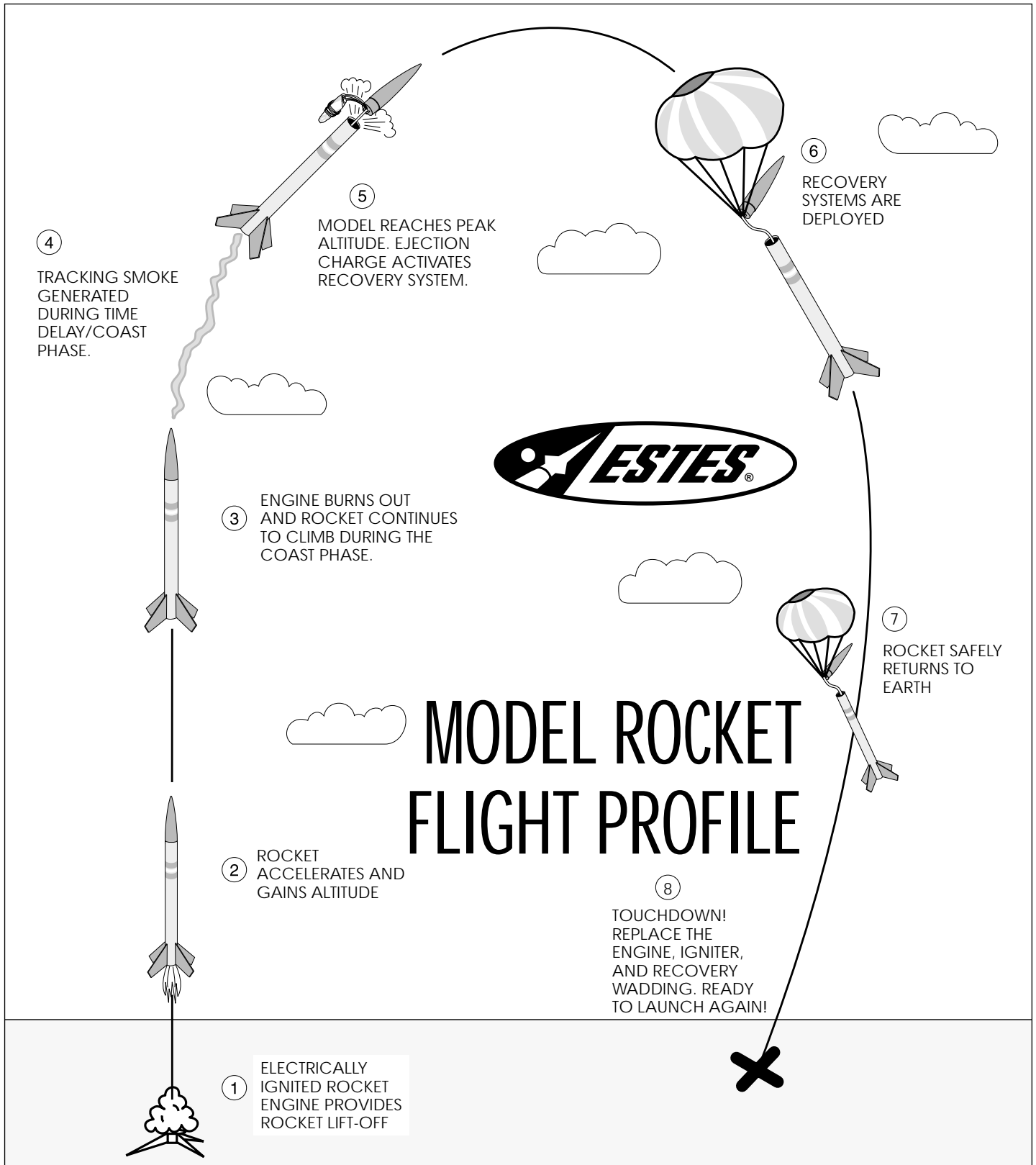

The Alpha Model Rocket Nomenclature

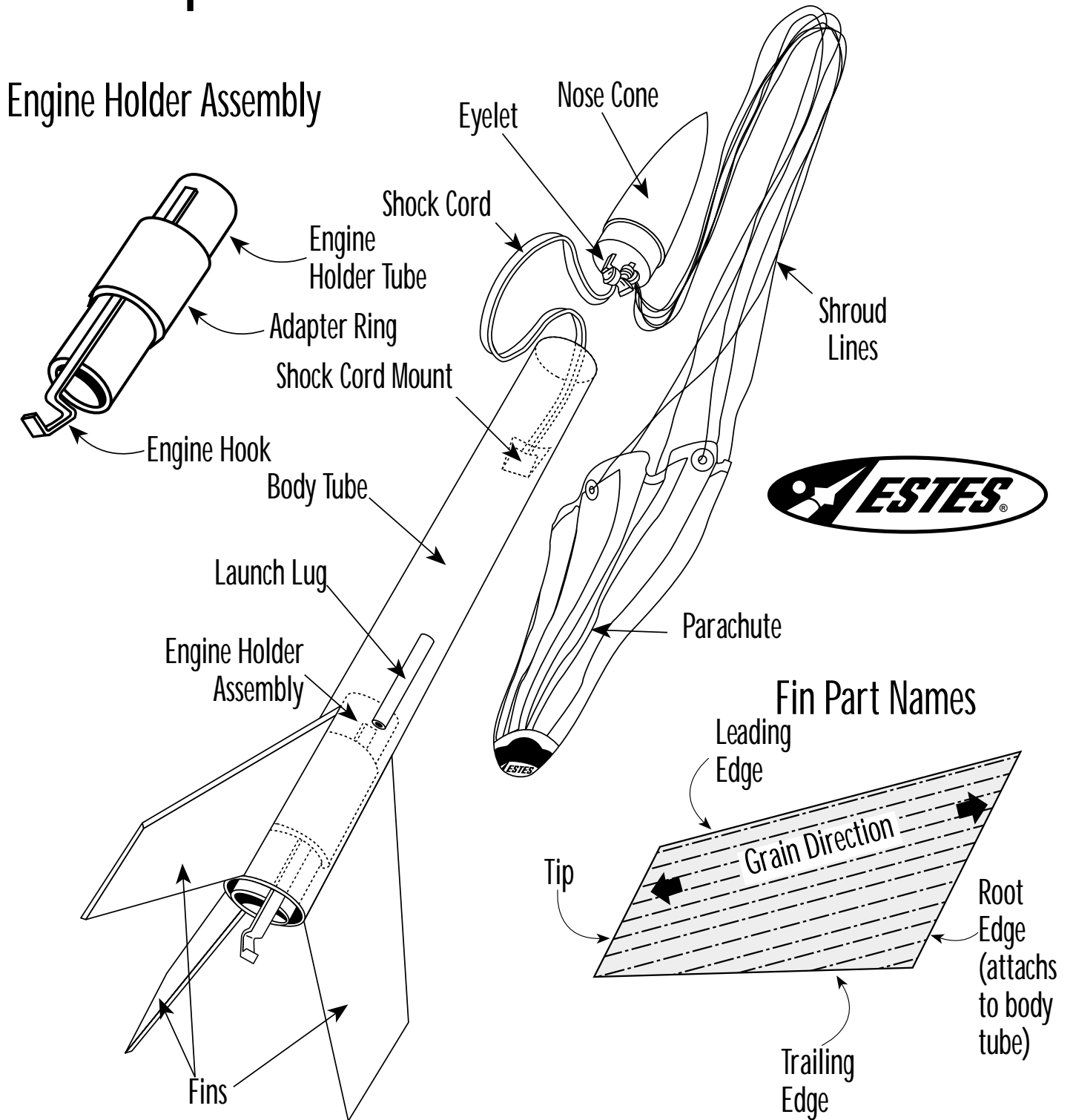

The Alpha Model Rocket Nomenclature

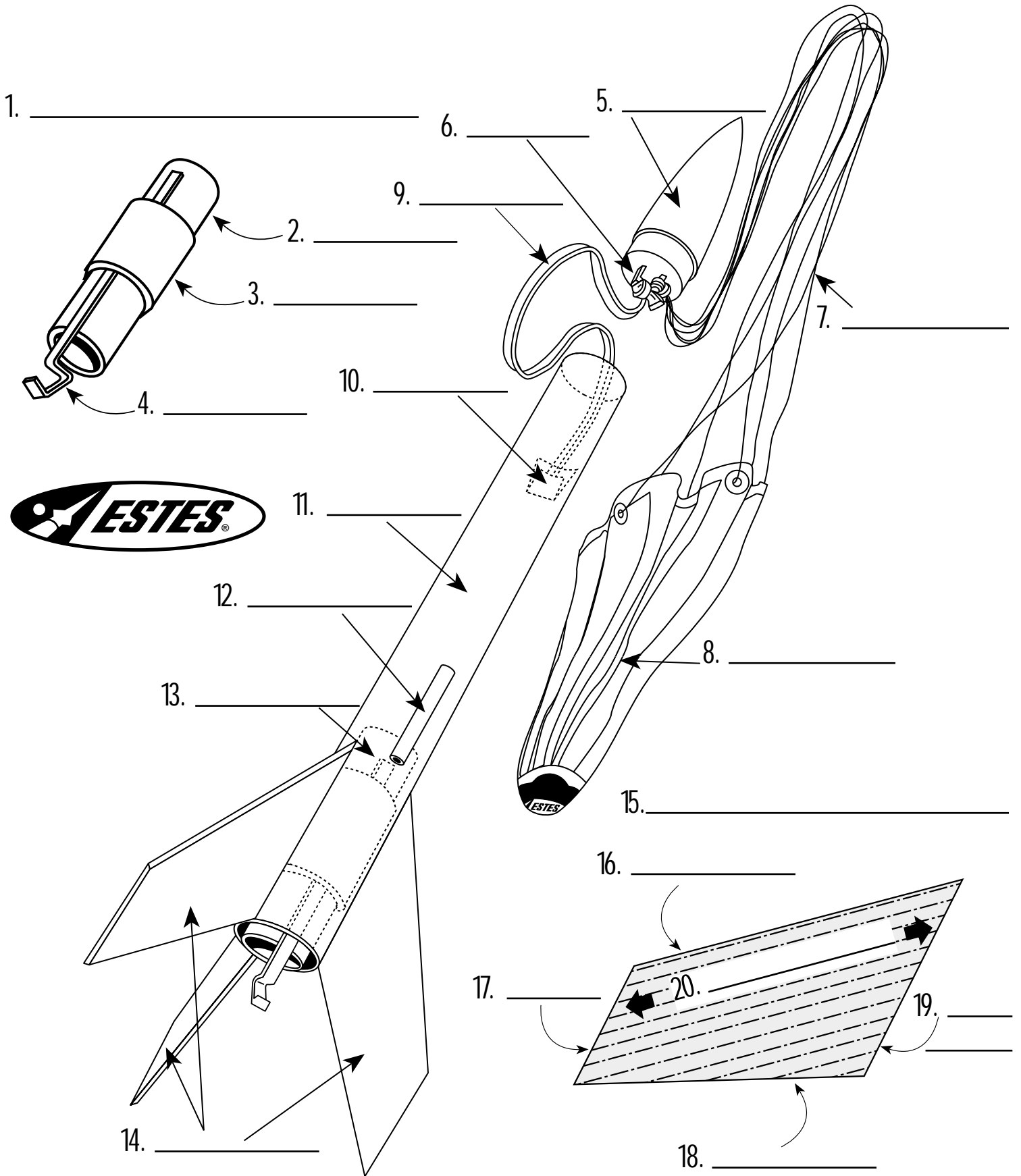



Model Rocketry Safety Code*

1. Materials--My model rocket will be made of lightweight materials such as paper, wood, rubber, and plastic suitable for the power used and the performance of my model rocket. I will not use any metal for the nose cone, body, or fins of a model rocket.

2. Motors/Engines--I will use only commercially-made NAR certified model rocket engines in the manner recommended by the manufacturer. I will not alter the model rocket engine, its parts, or its ingredients in any way.

3. Recovery--I will always use a recovery system in my model rocket that will return it safely to the ground so it may be flown again. I will use only flame-resistant recovery wadding if required.

4. Weight and Power Limits--My model rocket will weigh no more than 1500 grams (53 oz.) at lift-off, and its rocket engines will produce no more than 320 Newton-seconds (4.45 Newtons equal 1.0 pound) of total impulse. My model rocket will weigh no more than the engine manufacturer's recommended maximum lift-off weight for the engines used, or I will use engines recommended by the manufacturer for my model rocket.

5. Stability--I will check the stability of my model rocket before its first flight, except when launching a model rocket of already proven stability.

6. Payloads--Except for insects, my model rocket will never carry live animals or a payload that is intended to be flammable, explosive, or harmful.

7. Launch Site--I will launch my model rocket outdoors in a cleared area, free of tall trees, power lines, buildings, and dry brush and grass. My launch site will be at least as large as that recommended in the following table.

LAUNCH SITE DIMENSIONS

Installed Total Impulse (Newton-seconds)	Equivalent Engine Type	Minimum Site Dimension	
		(feet)	(meters)
0.00-- 1.25	1/4A & 1/2A	50	15
1.26-- 2.50	A	100	30
2.51-- 5.00	B	200	60
5.01-- 10.00	C	400	120
10.01-- 20.00	D	500	150
20.01-- 40.00	E	1000	300
40.01-- 80.00	F	1000	300
80.01-- 160.00	G	1000	300
160.01-- 320.00	2Gs	1500	450

8. Launcher--I will launch my model rocket from a stable launching device that provides rigid guidance until the model rocket has reached a speed adequate to ensure a safe flight path. To prevent accidental eye injury, I will always place the

launcher so that the end of the launch rod is above eye level or I will cap the end of the launch rod when approaching it. I will cap or disassemble my launch rod when not in use and I will never store it in an upright position. My launcher will have a jet deflector device to prevent the engine exhaust from hitting the ground directly. I will always clear the area around my launch device of brown grass, dry weeds, or other easy-to-burn materials.

9. Ignition System--The system I use to launch my model rocket will be remotely controlled and electrically operated. It will contain a launching switch that will return to "off" when released. The system will contain a removable safety interlock in series with the launch switch. All persons will remain at least 15 feet (5 meters) from the model rocket when I am igniting model rocket engines totalling 30 Newton-seconds or less of total impulse and at least 30 feet (9 meters) from the model rocket when I am igniting model rocket engines totalling more than 30 Newton-seconds of total impulse. I will use only electrical igniters recommended by the engine manufacturer that will ignite model rocket engine(s) within one second of actuation of the launching switch.

10. Launch Safety--I will ensure that people in the launch area are aware of the pending model rocket launch and can see the model rocket's liftoff before I begin my audible five-second countdown. I will not launch a model rocket using it as a weapon. If my model rocket suffers a misfire, I will not allow anyone to approach it or the launcher until I have made certain that the safety interlock has been removed or that the battery has been disconnected from the ignition system. I will wait one minute after a misfire before allowing anyone to approach the launcher.

11. Flying Conditions--I will launch my model rocket only when the wind is less than 20 miles (30 kilometers) an hour. I will not launch my model rocket so it flies into clouds, near aircraft in flight, or in a manner that is hazardous to people or property.

12. Pre-Launch Test--When conducting research activities with unproven model rocket designs or methods I will, when possible, determine the reliability of my model rocket by pre-launch tests. I will conduct the launching of an unproven design in complete isolation from persons not participating in the actual launching.

13. Launch Angle--My launch device will be pointed within 30 degrees of vertical. I will never use model rocket engines to propel any device horizontally.

14. Recovery Hazards--If a model rocket becomes entangled in a power line or other dangerous place, I will not attempt to retrieve it.

As a member of the Estes Model Rocketry Program, I promise to faithfully follow all rules of safe conduct as established in the above code.

Signature _____

*This is the official Model Rocketry Safety Code of the National Association of Rocketry and the Model Rocket Manufacturers Association.

Estes Note: The largest "model" rocket engine as defined by CPSC is an "F" (80 NS). To launch rockets weighing over one pound including propellant or rockets containing more than 4 oz. of propellant (net weight), you must obtain a waiver from the FAA. Check your telephone directory for the FAA office nearest you.



Model Rocket Engines

ENGINE CODING FOR QUICK-N-EASY IDENTIFICATION

1. Label color indicates recommended use of the engine.

- a. Green Single Stage rockets
- b. Purple. Upper Stage or Single Stage, if used in very light rockets
- c. Red *Booster and intermediate stages of multi-stage rockets
- d. Black *Special plugged engines for R/C gliders

*These contain no delay or ejection charge.

2. Code designation stamped on the engine gives useful and important information on its performance capabilities.



- a. This portion indicates total impulse or total power produced by the engine.
- b. This portion shows the engine's average thrust in Newtons and helps you choose the proper engine for your rocket's flight.
- c. This number gives you the delay in seconds between burnout and ejection charge. It lets you choose the engine with the delay time you want for any flight.

TOTAL IMPULSE CLASSIFICATION

Code	Pound-Seconds	Newton-Seconds
1/2A	0.14 - 0.28	0.625 - 1.25
A	0.28 - 0.56	1.26 - 2.50
B	0.56 - 1.12	2.51 - 5.00
C	1.12 - 2.24	5.01 - 10.00
D	2.24 - 5.00	10.01 - 20.00

HOW HIGH WILL YOUR ROCKET GO?

The chart below shows the approximate altitudes that can be achieved with single stage rockets.

Engine Size	Altitude Range depending on rocket size and weight)	Approximate Altitude in a typical 1 oz. model
1/2A6-2	100' to 400'	190'
A8-3	200' to 650'	450'
B6-4	300' to 1000'	750'
C6-5	350' to 1500'	1000'

(Some high performance rockets will reach higher altitudes than shown above.)

Model Rocket Engine Functions

Graphic explanation of a rocket engine's fundamental construction and functions

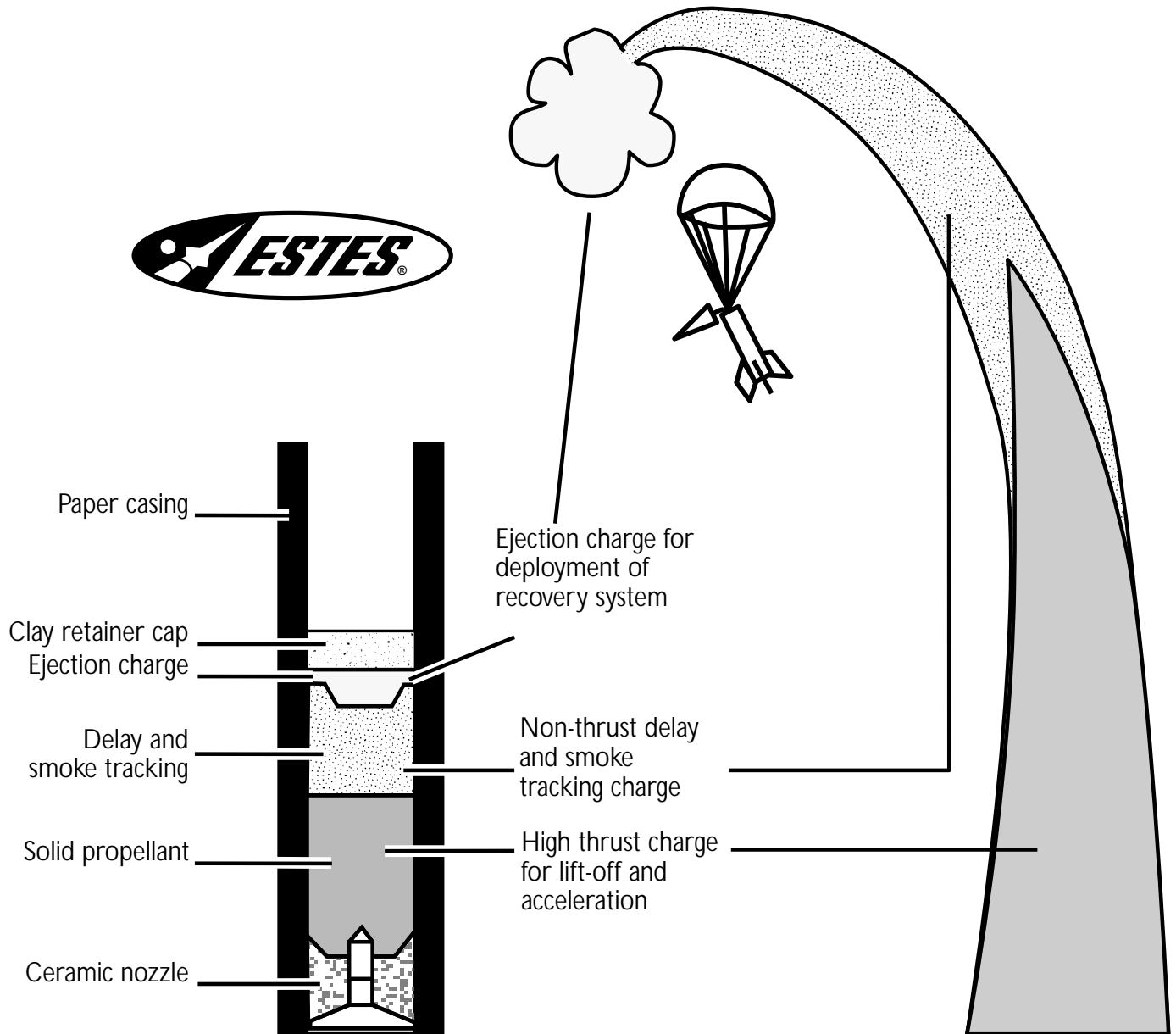

Typical Time/Thrust Curve B6-4 Model Rocket Engine

Specific Impulse: 80-83 lb.-sec. per lb.
Exhaust Velocity: 2550-2650 ft./sec.

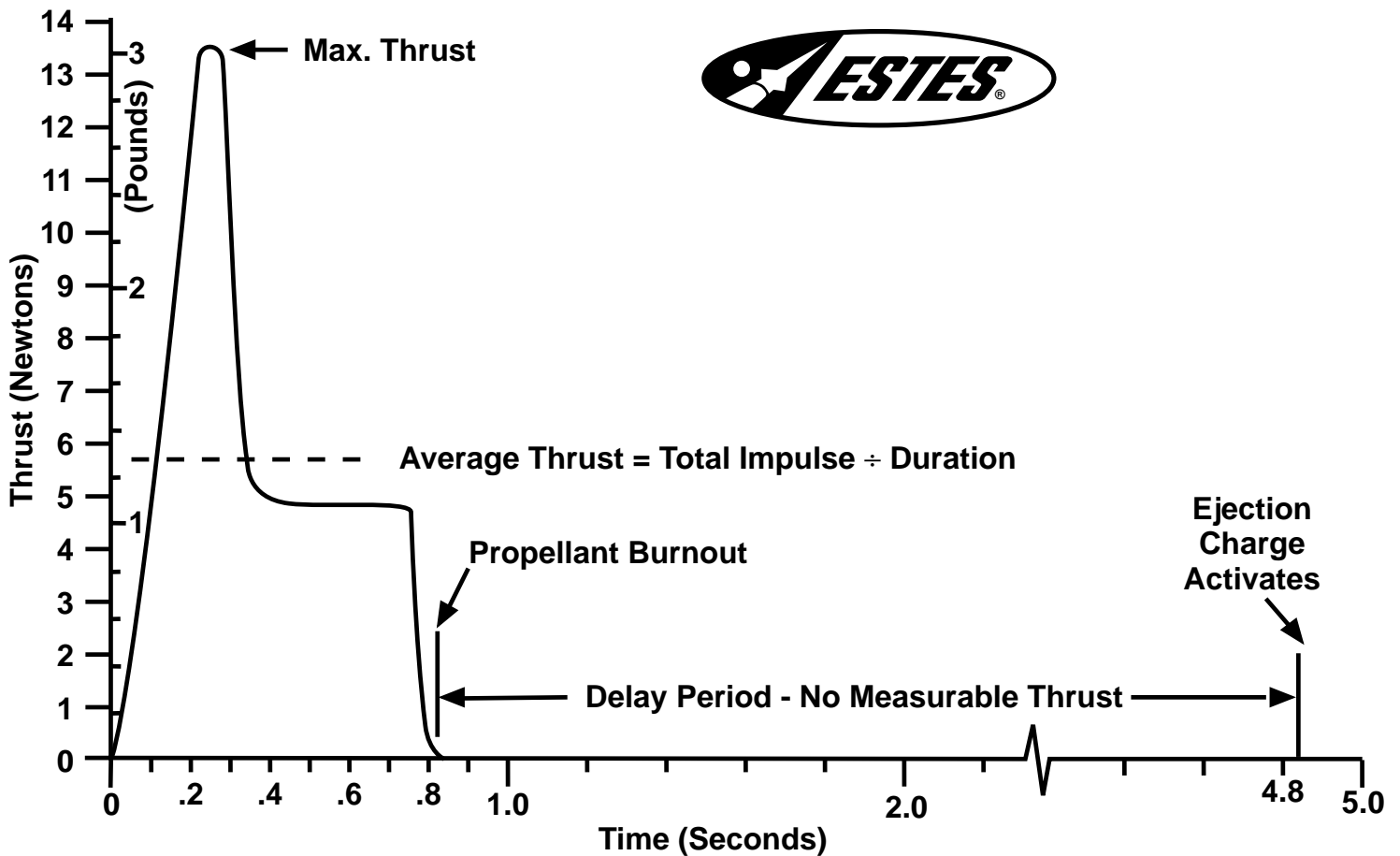
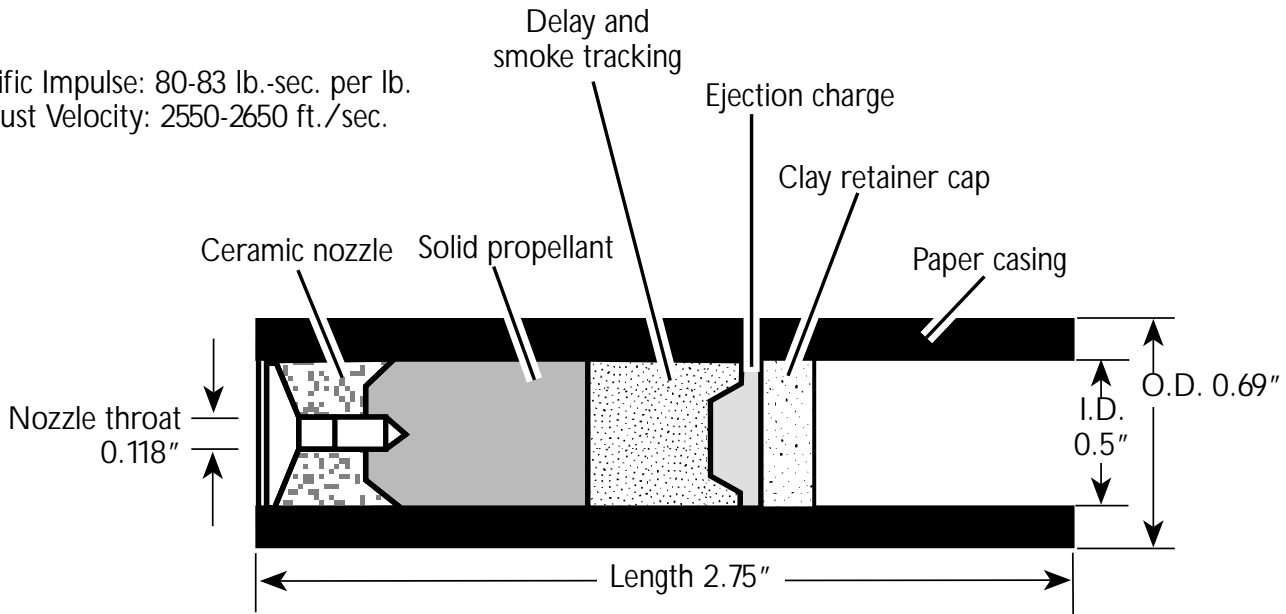

Igniter Installation

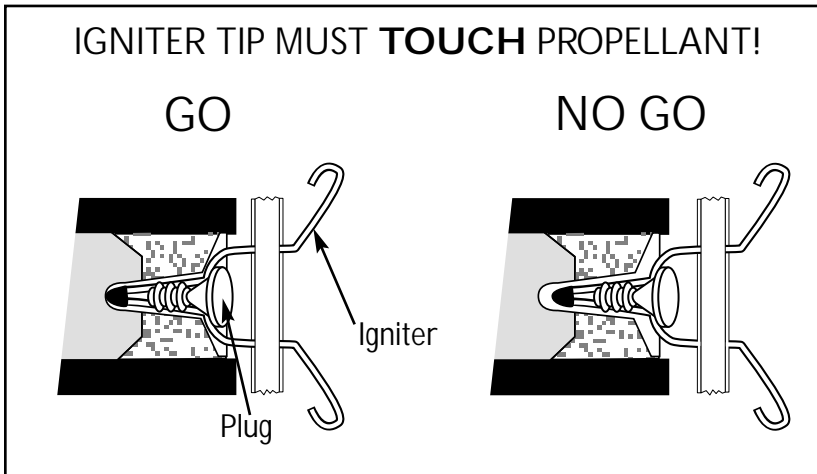

About 90% of all problems with engine ignition are caused by the igniter not being properly and securely held in place in the engine.

The igniter must **touch** the propellant at the moment the igniter is heated for ignition.

Attach micro-clips to igniter leads as close as possible to nozzle.

MODEL ROCKET IGNITER INSTALLATION

Always use electrical model rocket igniters with a model rocket launch controller.

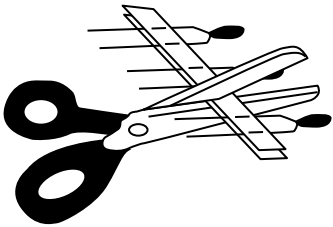

1. Cut tape separating igniters. Do not remove tape.



2. Separate plug from strip of plugs.

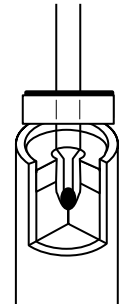

3. Insert igniter into engine. Igniter must touch propellant.

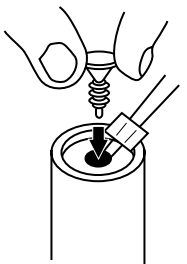

4. Insert plug into engine nozzle.

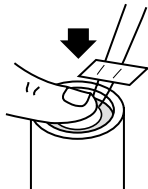

5. Push plug firmly into engine.

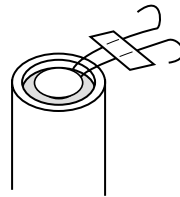

6. Bend igniter wires.

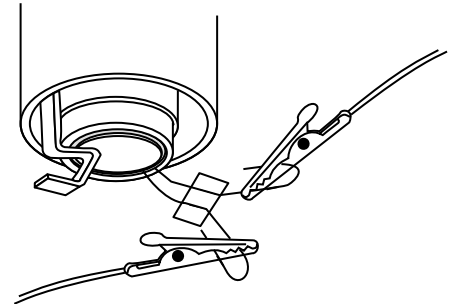

7. Attach one micro-clip to each lead of igniter. Clips must not touch each other or blast deflector and igniter leads must not cross.

